

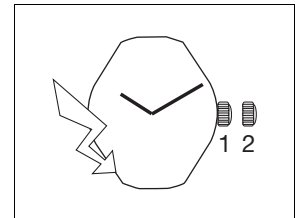

6 3/4" x 8" ETA 902.002

CT 902002 ESI 583733 05 05.11.2013



6 3/4" x 8" Ø 15,30 x 17,80 mm

Movement height	Altura sobre máquina	Altezza sopra movimento	2,35 mm
Height on battery	Altura sobre pila	Altezza sopra pila	2,35 mm
Number of jewels	Número de piedras	Numero di pietre	4
Frequency	Frecuencia	Frequenza	32'768 Hz

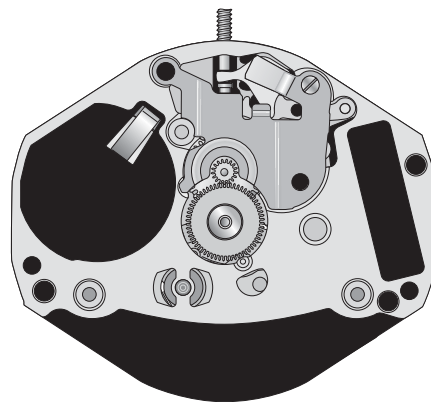
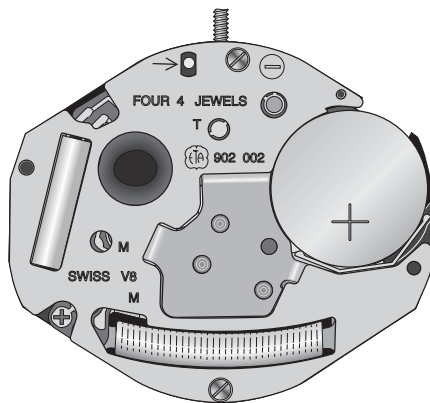

The repair and reconditioning work must only be performed by properly trained personnel.  
Las tareas de reparación y revisión sólo deben ser llevadas a cabo por personal debidamente formado.  
I lavori di riparazione e di revisione devono essere eseguiti esclusivamente da personale adeguatamente formato.



## General information



**Before** starting work, please study this "Technical communication" carefully.



Eye protection is obligatory for all operations / work on the movement!



ETA SA disclaims any liability in case of damage arising from failure to observe this "Technical communication".

## Environmental protection requirements



**The legal provisions relating to waste handling and disposal must be observed in all operations / work on the movement!**

In particular, lubricating and cleaning products harmful to the environment must be disposed of in accordance with the rules!



**Substances prone to cause water pollution** must be stored, transported, collected and disposed of in appropriate vessels.

**Under no circumstances must they pollute the soil or be poured into sewage systems!**

## Explanation of symbols



**Caution! Risk of material damage!**

Below are some obligatory instructions for preventing any material damage!

## Información general



Esta "Comunicación técnica" deberá estudiarse muy bien **antes** de comenzar los trabajos.



Es obligatorio utilizar protección ocular para todos los trabajos en y con el reloj.



ETA SA no se hace responsable de los daños provocados como consecuencia de la inobservancia de esta "Comunicación técnica".

## Normas de protección medioambiental



**Deberá cumplirse la normativa legal relativa al reciclaje y la eliminación correctos de los residuos en todos los trabajos en y con el reloj.**

En especial, deberán eliminarse correctamente los productos lubricantes y de limpieza peligrosos para el medio ambiente.



**Las sustancias contaminantes del agua** deben recogerse, almacenarse, transportarse y eliminarse en recipientes adecuados.

**En ningún caso se permitirá que contaminen el suelo o que lleguen a la canalización.**

## Significado de los símbolos



**Atención Peligro de daños materiales**

Instrucciones que deberán respetarse necesariamente para evitar daños materiales.

## Informazioni generali



Questa "Comunicazione Tecnica" deve essere studiata attentamente **prima** dell'inizio dei lavori.



Per tutti i lavori su e con il movimento dell'orologio è obbligatorio proteggere gli occhi!



ETA SA declina qualunque responsabilità per eventuali danni causati dalla mancata osservanza della presente "Comunicazione tecnica".

## Disposizioni relative alla protezione ambientale



**Per tutti i lavori su e con il movimento dell'orologio si dovranno rispettare le disposizioni di legge relative al corretto riciclaggio e smaltimento dei rifiuti!**

In particolare si dovrà provvedere al corretto smaltimento di lubrificanti e detersivi nocivi per l'ambiente!



**Le sostanze inquinanti per l'acqua** devono essere conservate, trasportate, raccolte e smaltite in contenitori adatti.

**Queste non devono inquinare il terreno o arrivare nelle canalizzazioni!**

## Spiegazione dei simboli



**Attenzione! Pericolo di danni materiali!**

Seguono importanti indicazioni che devono essere tassativamente rispettate per evitare danni materiali!

List of components - Lista de piezas - Lista fornitori

Pos	No	No CS	Article number Número de artículo Numero articolo		List of components	Lista de piezas	Lista fornitori
-	100	10.020.07	Var		Main plate, jewelled	Platina, empedrada	Piastra, con pietre
-	110	10.048.00	-		Train wheel bridge	Puente de rodaje	Ponte del ruotismo
-	203	30.012.00	-		Intermediate wheel	Rueda intermedia	Ruota intermedia
-	210	30.025.00	-		Third wheel	Rueda primera	Ruota mediana
-	227/3	30.027.18	-		Second wheel, without sweep second	Rueda de segundos, sin segundero central	Ruota dei secondi, senza secondi al centro
-	242/1	31.083.00	Var		Cannon pinion with driving wheel, without sweep second	Cañón de minutos, con rueda de arrastre, sin segundero central	Pignone calzante con ruota conduttrice, senza secondi al centro
-	250/1	31.046.06	Var		Hour wheel, assembled	Rueda de horas, montada	Ruota delle ore, montata
-	259	81.171.00	-		Hour wheel spring clip	Chaveta de rueda de horas	Chiavetta della ruota delle ore
-	260	31.041.00	-		Minute wheel	Rueda de minutería	Ruota della minuteria
-	405	51.020.00	Var		Handsetting stem	Tija de puesta en hora	Albero di messa all'ora
-	407	31.121.00	-		Sliding pinion	Piñón corredizo	Pignone scorrevole
-	435	51.050.00	-		Yoke	Báscula de piñón corredizo	Bascula del pignone scorrevole
-	443/1	51.080.06	-		Setting lever, assembled	Tirete, montado	Tiretto, montato
-	462	10.062.00	-		Minute train bridge	Puente del rodaje de minutería	Ponte del ruotismo di minuteria
-	4000	10.513.00	Var		Electronic module	Módulo electrónico	Modulo elettronico
-	4021	20.582.00	-		Stator	Estátor	Statore
-	4211	20.580.00	Var		Rotor	Rotor	Rotore
-	4255	10.700.00	-		Electronic module cover	Cubre-módulo electrónico	Copri-modulo elettronico
-	4401	20.761.00	-		Bridle +	Brida +	Brida +
-	4929	20.570.00	-		Battery Ø 6.80 mm, H. 1.65 mm	Pila Ø 6,80 mm, H. 1,65 mm	Pila Ø 6,80 mm, H. 1,65 mm
1)	5110	10.048.01	Var	2x	Screw for train wheel bridge	Tornillo de puente de rodaje	Vite del ponte del ruotismo
-	5462	10.062.01	-	1x	Screw for minute train bridge	Tornillo del puente de rodaje de minutería	Vite per il ponte del ruotismo di minuteria
1)	54000	10.513.01	Var	3x	Screw for electronic module	Tornillo del módulo electrónico	Vite del modulo elettronico
-	54255	10.700.01	-	2x	Screw for electronic module cover	Tornillo del cubre-módulo electrónico	Vite del copri-modulo elettronico
					Identical screws Tornillos idénticas Viti identiche	1) 5110 54000	
			Var		Variant	Variante	Variante

**Interchangeability and variants  
can be found on the  
ETA ONLINE SHOP (EOS):**

**www.eta.ch**

- Support Center
- Support Center Portal

**La intercambiabilidad y las  
variantes se encuentran en  
ETA ONLINE SHOP (EOS):**

**www.eta.ch**











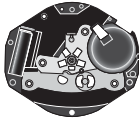











- Support Center
- Support Center Portal

**L'intercambiabilità e le varianti si  
trovano sul  
ETA ONLINE SHOP (EOS):**

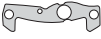
**www.eta.ch**

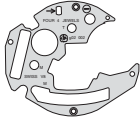
- Support Center
- Support Center Portal

Materials - Fornituras - Forniture

								
100 Var	110	203	210	227/3	242/1 Var	250/1 Var	259	5110 Var 54000 Var
								
260	405 Var	407	435	443/1	462	4000 Var	5462	
								
4021	4211 Var	4255	4401	4929	54255			

Order of assembly - Orden del montaje - Ordine dell'assemblaggio:  
Handsetting mechanism - Mecanismo de puesta en hora - Meccanismo della messa all'ora

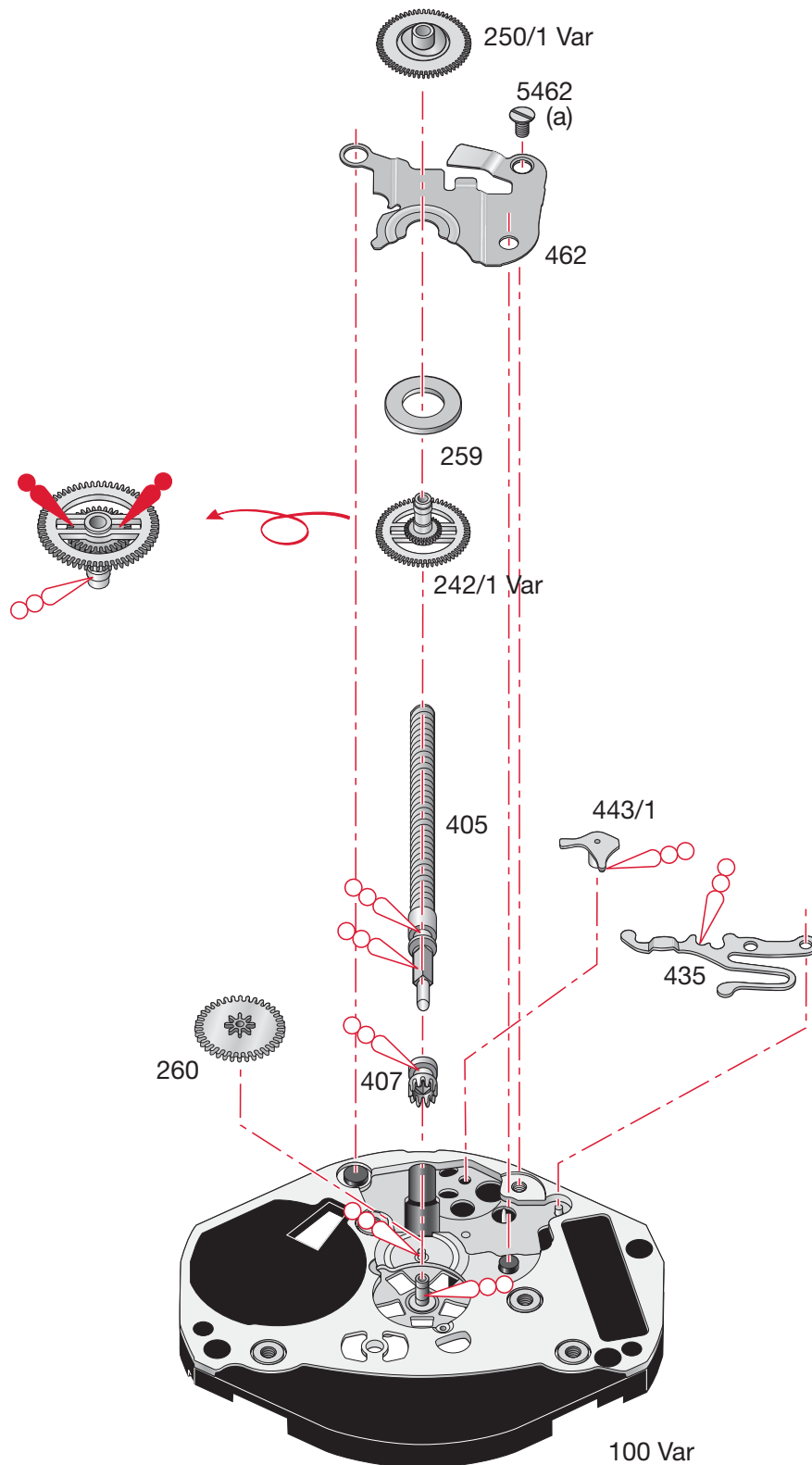

**Assembling of the handsetting mechanism**

(Parts listed in order of assembly)

**Montaje del mecanismo de puesta en hora**

(Lista de fornituras por orden de ensamblado)

**Montaggio del meccanismo della messa all'ora**

(Elenco delle forniture in ordine di montaggio)

100 Var	435	462
407	242/1 Var	5462 (1x)
405	259	250/1 Var
443/1	260	

**Lubrication - Lubricación - Lubrificazione**

Thick oil or grease  
Aceite espeso o grasa  
Olio denso o grasso

**Moebius  
HP-1300**  
or / ó / o  
**Moebius D5**



Very small quantity  
Cantidad muy pequeña  
Piccolissima quantità

**Moebius  
HP-1300**  
or / ó / o  
**Moebius D5**



Grease  
Grasa  
Grasso

**Moebius 9501**  
or / ó / o  
**Jismaa 124**

**M<sub>L</sub> Minimum torque for loosening****M<sub>L</sub> Par mínimo para desatornillar****M<sub>L</sub> Coppia minima per svitare**

(a) 0,7 Ncm

Order of assembly - Orden del montaje - Ordine dell'assemblaggio:  
 Basic movement and the electronic module - Máquina de base y del módulo electrónico - Movimento di base e del modulo elettronico

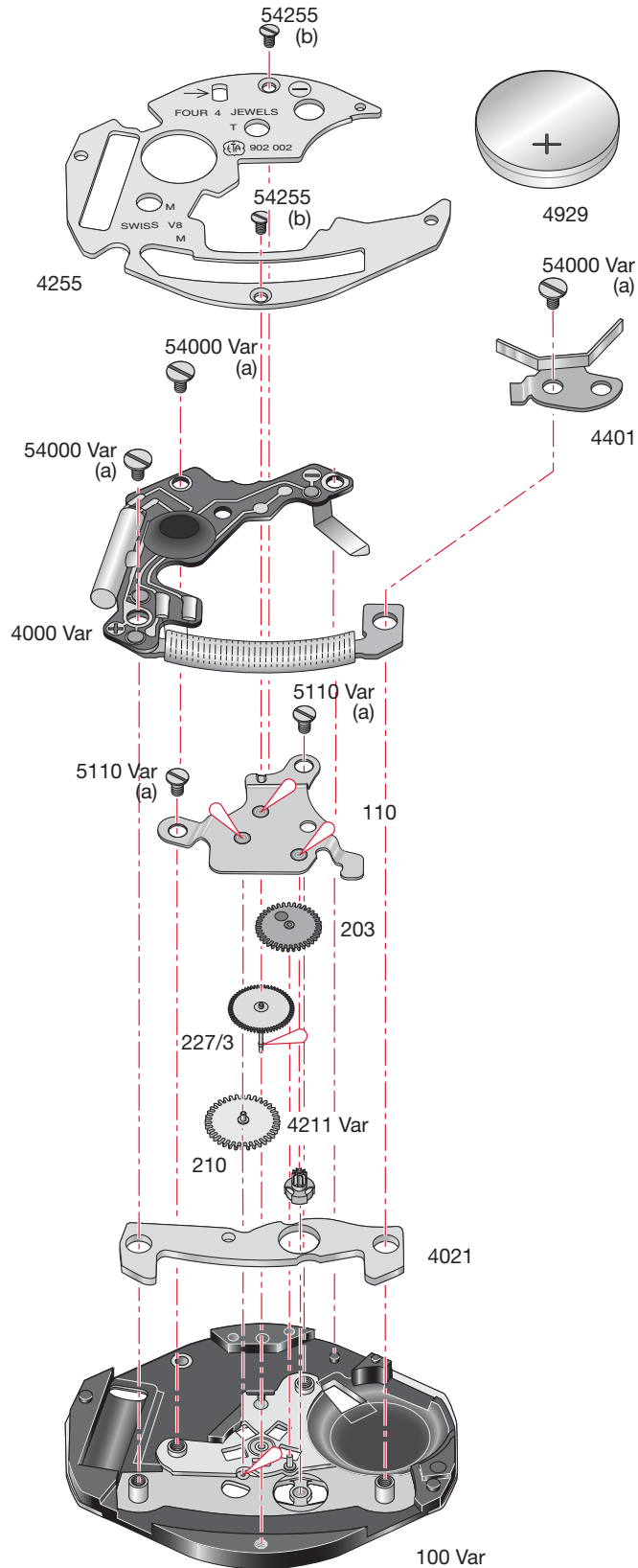



**Assembling of the basic movement and the electronic module**

(Parts listed in order of assembly)

**Montaje de la máquina de base y del módulo electrónico**

(Lista de fornitureas por orden de ensamblado)

**Montaggio del movimento di base e del modulo elettronico**

(Elenco delle forniture in ordine di montaggio)

100 Var	203	54000 Var (3x)
4021	110	4255
4211 Var	5110 Var (2x)	54255 (2x)
210	4000 Var	4929
227/3 Var	4401	

**Lubrication - Lubricación - Lubrificazione**

	Fine oil Aceite fino Olio fluido	<b>Moebius 9014</b>
---	--	---------------------

**M<sub>L</sub> Minimum torque for loosening**

**M<sub>L</sub> Par mínimo para desatornillar**

**M<sub>L</sub> Coppia minima per svitare**

- (a) 0,7 Ncm
- (b) 0,6 Ncm

## Electrical tests - Controles eléctricos - Controlli elettrici

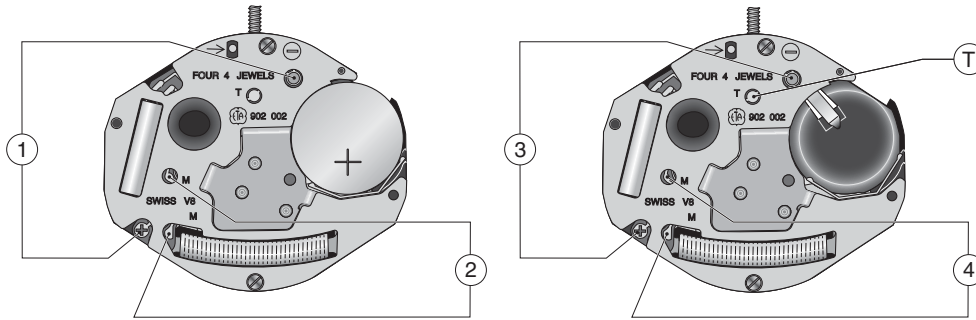

Position Posición Posizione	Setting of apparatus Escala de medición Scala di misura	Measurement Medición Misura	Test Control Controllo	Remarks Notas Osservazioni
1	2 V ( $R_i \geq 10 \text{ k}\Omega/\text{V}$ )	1,55 V	Battery voltage. Tensión de la pila. Tensione della pila.	Measurement with battery. Medición con pila. Misura con una pila.
2	1 V ( $R_i \geq 10 \text{ k}\Omega/\text{V}$ )	Hand of measuring apparatus oscillates in + and - direction.  La aguja del multímetro oscila en sentido T y -.  La lancette del multímetro oscila nel senso + e -.	Impulses at output of integrated circuit:  Impulso a la salida del circuito integrado:  Impulsi all'uscita del circuito integrato:  1/5 s	Measurement with controlled battery.  Medición con una pila controlada.  Misura con una pila controlata.
3	2 V	$\leq 1,30 \text{ V}$  For accelerating the motor, connect point T to - printer circuit conductor.  La aguja del multímetro oscila en sentido T y -.  Per accelerare il motore, connettere il punto T alla pista -.	Lower working-voltage limit.  Limite inferiore de la tensión de funcionamiento.  Limite inferiore della tensione di funzionamento.	Measurement without battery, with variable external power supply, starting with 1.55 V, lower tension until movement stops.  Medición sin pila, con alimentación exterior variable bajando de 1,55 V hasta la parada de la máquina.  Misura senza pila con alimentazione esterna variabile, scendendo da 1,55 V fino all'arresto del movimento.
	10 $\mu\text{A}$	$\leq 0,70 \mu\text{A}$	Consumption of movement.  Consumo de la máquina.  Consumo del movimento.	Measurement without battery, with power-supply unit 1.55 V.  Medición sin pila, con alimentación exterior 1,55 V.  Misura senza pila con alimentazione esterna 1,55 V.
4	• 10 k $\Omega$	0,90 – 1,40 k $\Omega$	Condition of coil. Aislamiento de la bobina. Isolazione della bobinatura.	
Ohmmeter with a test voltage higher than 0.40 V unsuitable, recommended voltage 0.20 V. Ohmiómetros con tensión de medición superior a 0,4 V inapropiados, tensión recomendada 0,20 V. Ohmmetri con tensione di misura superiore a 0,4 V inappropriati, tensione raccomandata 0,20 V.				

The test must be conducted at an ambient temperature of between 20°C and 25°C.  
 Las pruebas deben realizarse a una temperatura ambiente comprendida entre 20°C y 25°C.  
 I test devono essere effettuati a temperatura ambiente compresa tra 20°C e 25°C.

The watches must not be stocked with the crown in position 2\* (the current consumption is higher !)

\* Winding stem pulled out.

Los relojes no deben almacenarse con la corona en la posición 2\* (se aumenta el consumo !)

\* Tija extraída.

Gli orologi non devono essere riposti con la corona in posizione 2\* (aumento del consumo !)

\* Albero tirato verso l'esterno.

We reserve all rights for this document. It is meant for the recipient only and it may not be copied, printed or given to a third person without our written permission. Quedan reservados todos los derechos relacionados con este documento, que está dirigido únicamente al destinatario. Queda por lo tanto prohibida su copia, impresión o terceros sin nuestra autorización por escrito. Ogni diritto su questo documento è riservato. Il documento è indirizzato esclusivamente al destinatario e non può essere copiato, stampato o ceduto a terzi senza un'autorizzazione scritta.

Ajustement aiguille des heures  
 Stundenzeigerpassung  
 Hour hand fitting

Ajustement aiguille des minutes  
 Minutenzeigerpassung  
 Minute hand fitting

cylindrique  
 zylindrisch  
 cylindrical

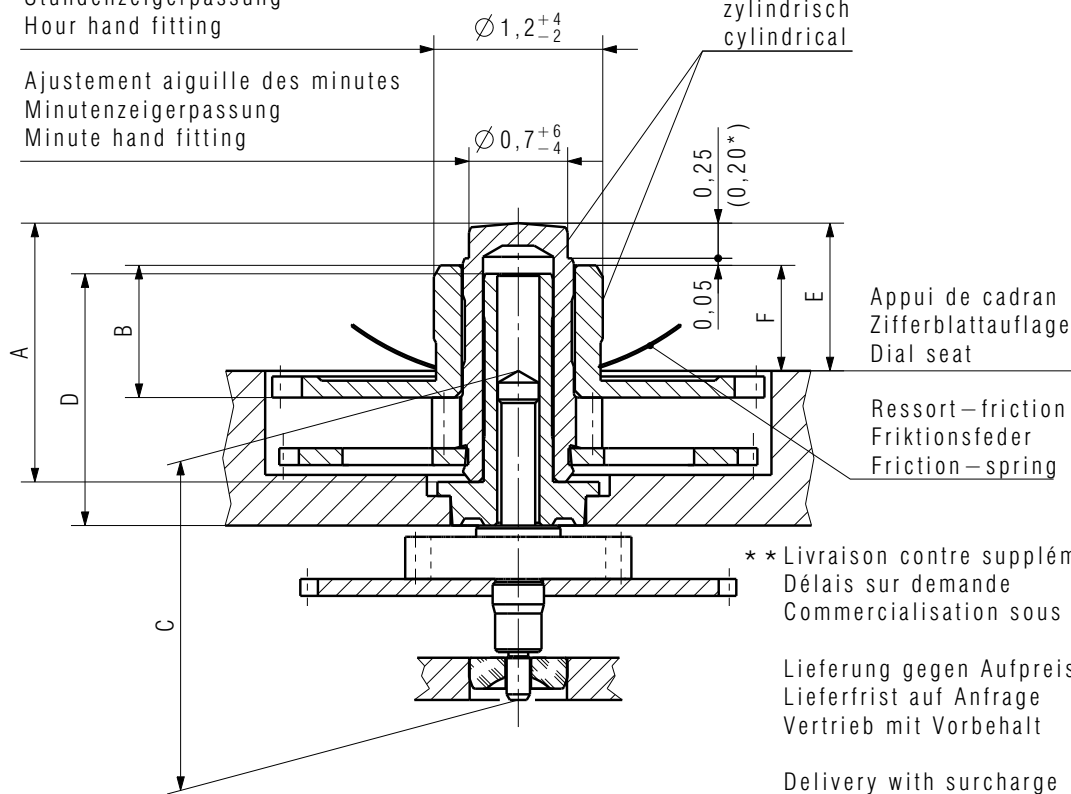

Appui de cadran  
 Zifferblattaufgabe  
 Dial seat

Ressort-friktion  
 Friktionsfeder  
 Friction-spring

\*\* Livraison contre supplément de prix  
 Délais sur demande  
 Commercialisation sous réserve

Lieferung gegen Aufpreis  
 Lieferfrist auf Anfrage  
 Vertrieb mit Vorbehalt

Delivery with surcharge  
 Delivery schedul on demand  
 Market launch with specific conditions

Aiguillage Zeigerwerkhöhe Hand fitting height	Longueur/Länge/Length				Dépassement Höhe über Zifferblattaufgabe Height over dial seat		Ep.cadran Zifferblattdicke Dial thickness
	A	B	C	D	E	F	
	Chaussée Minutenrohr Cannon-pinion	Roue des heures Stundenrad Hour wheel	Pig.des sec. Sekundentrieb Sec.wheel pin.	Tube de centre Zentrumrohr Centre tube	Chaussée Minutenrohr Cannon-pinion	Roue des heures Stundenrad Hour wheel	
réduit * niedrig * reduced *	1,72	0,84	2,34	1,79	0,9	0,65	0,3
1 normal	1,84	0,94	2,34	1,79	1,05	0,75	0,4
2	1,99	1,09	2,34	1,79	1,2	0,9	
5**	2,74	1,84	2,34	1,79	1,95	1,65	

Aiguilles Zeiger Hands	Aiguille des heures Stundenzeiger Hour hand		Aiguille des minutes Minutenzeiger Minute hand	
Masse/Masse/Mass	max.	mg	15	15
Balourd/Unwucht/Unbalance	max.	µNm	0,24	0,24
Force de chassage/Setzkraft/Press-in force	max.	N	30	30

Kaliber / Calibre / Caliber <b>902.002</b>	Masstab Echelle Scale --		CATIA V5
		Masse in mm Dimensions en mm Dimensions in mm	Tol.1/1000 mm

<b>AIGUILLAGES ZEIGERWERKHÖHEN HAND FITTING HEIGHTS</b>	Version <b>01</b>	Révision <b>00</b>	Blatt Feuille Sheet <b>01/01</b>
<b>Z0091701</b>			

<b>ETA SA</b> MANUFACTURE HORLOGÈRE SUISSE DEPUIS 1793	Ersatz für/En remplacement de/Remplacement for	Klass. <b>ZVACC</b>	<b>KUN</b>
	Aenderung/Modification	Erstellt Etabli Created <b>09.10.2006 NOR</b>	Geprüft Contrôlé Controlled <b>23.10.2006 NOR</b>
<b>A COMPANY OF THE SWATCH GROUP</b>		21601	

This page has deliberately been left blank in case of A3 format printing.

Esta página se han dejado en blanco a propósito en caso de imprimirla en formato A3.

Questa pagina è lasciata intenzionalmente bianca in caso di stampa formato A3.

This page has deliberately been left blank in case of A3 format printing.

Esta página se han dejado en blanco a propósito en caso de imprimirla en formato A3.

Questa pagina è lasciata intenzionalmente bianca in caso di stampa formato A3.

This page has deliberately been left blank in case of A3 format printing.

Esta página se han dejado en blanco a propósito en caso de imprimirla en formato A3.

Questa pagina è lasciata intenzionalmente bianca in caso di stampa formato A3.

**Modifications compared with previous document versions****Modificaciones comparadas con las versiones anteriores del documento****Modifiche comparate con le versioni precedenti del documento**

Version Versión Versione	Date Fecha Data	Modification	Modificación	Modifica	Page Página Pagina
05	05.11.2013	Basic version	Versión de base	Versione di base	--

All modifications reserved.

Salvo modificación.

Con riserva di ogni eventuale modifica.

This document can be found on the Support Center Portal (SCP):

[www.eta.ch](http://www.eta.ch)

- Support Center
- Support Center Portal
- Technical Documents

Este documento se encuentran en el Support Center Portal (SCP):

[www.eta.ch](http://www.eta.ch)

- Support Center
- Support Center Portal
- Technical Documents

Il presente documento si trovano sul Support Center Portal (SCP):

[www.eta.ch](http://www.eta.ch)

- Support Center
- Support Center Portal
- Technical Documents



**ETA**<sup>SA</sup>  
MANUFACTURE HORLOGÈRE SUISSE  
DEPUIS 1793

SC PRODUCT COMMUNICATION

Bahnhofstrasse 9  
2540 Grenchen  
Switzerland

Phone +41 (0)32 655 71 11  
Fax +41 (0)32 655 71 74

contact@eta.ch  
[www.eta.ch](http://www.eta.ch)